

DRAWING TYPE

CUSTOMER DRAWING

MARK	DATE	DESCRIPTION	DESIGN
A	2023.11.13	PROPOSAL	CHEN

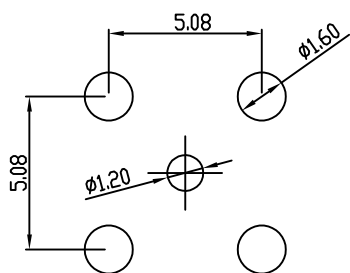
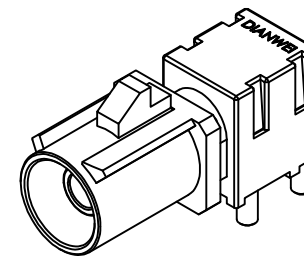
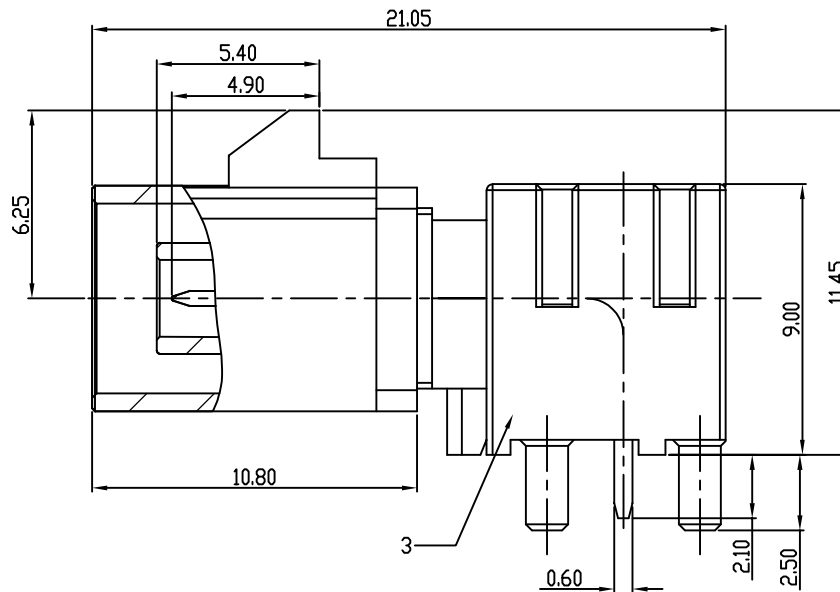
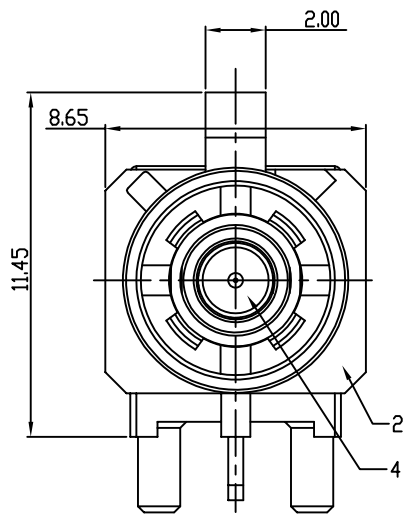

P.C.B LAYOUT

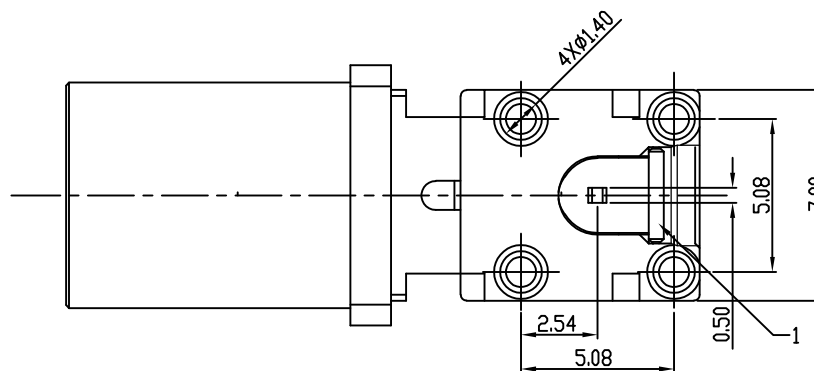

1. PART NO. LEGEND:
7.03A2 .000 8 2 X

TYPE
CONTACT AREA PLATING SPEC: GOLD PLATING: 8=30u"
SOLDER AREA PLATING SPEC: Tin PLATING: 8=80u"

2. PERFORMANCE:
- 2.1: CONTACT RESISTANCE: INITIAL VALUE 50mOHM Max,
 - 2.2: FREQUENCY RANGE: DC to 6GHz
 - 2.3 VSWR: 0-6GHz 1.60Max
 - 2.4 VOLTAGE RATING: 50V (AC/DC).
 - 2.5: CURRENT RATING: 1A/PIN.
 - 2.6: INSULATION RESISTANCE: 100MOHM Min.
 - 2.7: MATING CYCLES: 25 TIMES Min.
 - 2.8: OPERATING TEMPERATURE: -40°C ~ +105°C

NO.	COMPONENTS	MATERIALS	FINISH/COLOR	SPECIFICATION	QUANTITY
4	MOLDING	THERMOPLASTIC+BRASS	BLACK+PLATING GOLD		1
3	BODY	ZINC ALLOY	PLATING Sn		1
2	HOUSING	THERMOPLASTIC UL94V-0	ACCORDANCE WITH THE REQUIREMENTS		1
1	STATOR	BRASS	PLATING Sn		1

DIANWEI

东莞市钿威电子科技有限公司

DONGGUAN DIANWEI ELECTRONIC TECHNOLOGY CO., LTD

Tel: +86-769-8788 8322 Fax: +86-769-8788 8321 E-mail: sales@dianwei.cn Http://www.dianwei.cn

UNLESS OTHERWISE SPECIFIED TOLERANCE			
ANG	TOL	DIM	TOL
.X	±3.0°	.X	±0.30
.XX	±2.0°	.XX	±0.20
.XXX	±1.0°	.XXX	±0.10

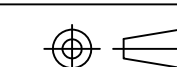

APPROVED

VERIFIED

DRAWING NO

7.03A2-C

DESIGN

CHEN

PART NAME:

PART NO.

DATE

2023.11.13

FAKRA HORIZONTAL TYPE CONNECTOR
CUSTOMER DRAWING

7.03A2.00082X

UNITS

mm

SCALE

1:1

PAGE

1/2

REV

A

NOTE: ALL RIGHTS RESERVED, BANNED COPY!

QP-04-33-B

DRAWING TYPE CUSTOMER DRAWING

MARK	DATE	DESCRIPTION	DESIGN
A	2023.11.13	PROPOSAL	CHEN

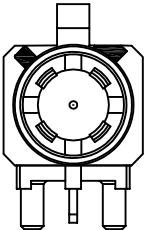
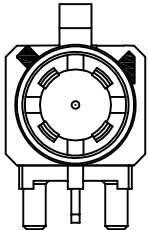
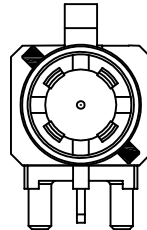
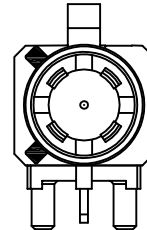
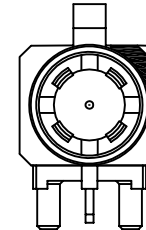
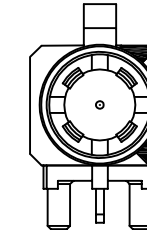
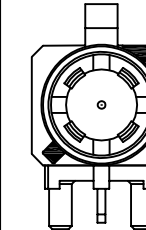
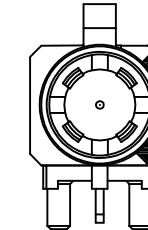
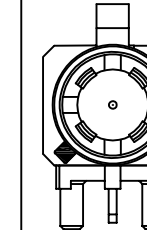
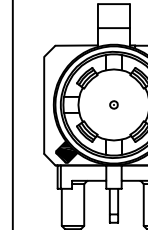
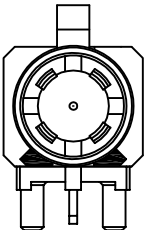
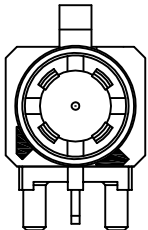
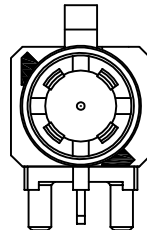
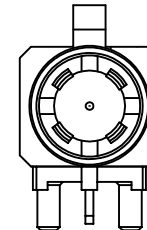
									
7.03A2.000820 A TYPE Black 黑色/9005	7.03A2.000821 B TYPE White 白色/9001	7.03A2.000822 C TYPE Blue 蓝色/5005	7.03A2.000823 D TYPE Bordeaux 枣红色/4004	7.03A2.000824 E TYPE Green 绿色/6002	7.03A2.000825 F TYPE Brown 棕色/8011	7.03A2.000826 G TYPE Grey 灰色/7031	7.03A2.000827 H TYPE Violet 紫罗兰/4003	7.03A2.000828 I TYPE Beige 米黄色/1001	7.03A2.000829 K TYPE Curry 咖喱色/1027
									
7.03A2.00082A L TYPE Camine Red 深红/3002	7.03A2.00082B M TYPE Pastel Orange 粉橙色/2003	7.03A2.00082C N TYPE Pastel Green 粉绿色/6019	7.03A2.00082D Z TYPE Water Blue 水蓝色/5021						

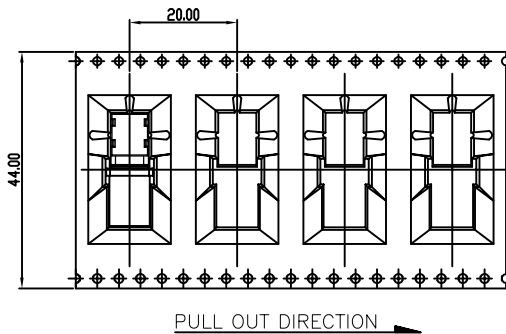

NOTE:
1.PER REEL:220PCS

NOTE: ALL RIGHTS RESERVED, BANNED COPY!

UNLESS OTHERWISE SPECIFIED TOLERANCE			
ANG	TOL	DIM	TOL
.X	±3.0°	.X	±0.30
.XX	±2.0°	.XX	±0.20
.XXX	±1.0°	.XXX	±0.10

DIANWEI

DONGGUAN DIANWEI ELECTRONIC TECHNOLOGY CO., LTD

Tel: +86-769-8788 8322 Fax: +86-769-8788 8321 E-mail: sales@dianwei.cn Http://www.dianwei.cn

东莞市钿威电子科技有限公司

DONGGUAN DIANWEI ELECTRONIC TECHNOLOGY CO., LTD

Tel: +86-769-8788 8322 Fax: +86-769-8788 8321 E-mail: sales@dianwei.cn Http://www.dianwei.cn

APPROVED	VERIFIED	DRAWING NO	PART NAME:	FAKRA HORIZONTAL TYPE CONNECTOR CUSTOMER DRAWING			
		7.03A2-C	PART NO.	7.03A2.00082X			
DESIGN	CHEN	DATE	UNITS	SCALE	PAGE	REV	
		2023.11.13	mm	4:1	2/2	A	

DRAWING TYPE PACKAGE DRAWING

MARK	DATE	DESCRIPTION	DESIGN
A	2023.11.13	PROPOSAL	CHEN

NOTES:

- MATERIAL:
 - CARRY TAPE:HIPS,T=0.50±0.05mm,BLACK
 - REEL:HIPS,
 - SHIM:PE,CLEAR.
- PRIMARY PACKING:220PCS/REEL.另外空格20PCS,总长4.8米.
- SECONDARY PACKING:SEE PACKING LIST
- PEELING RESISTANCE: 0.2~1.2N(20~120gf); PEELING ANGLE: 165°~180°; PEELING SPEED: 300mm/minutes.

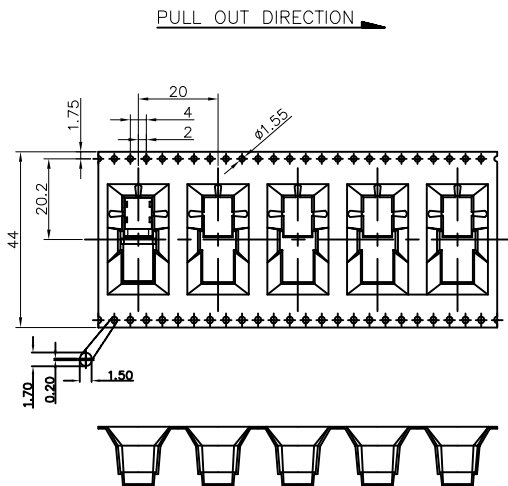

PER REEL with PE Bag

TOTAL 6 LAYERS

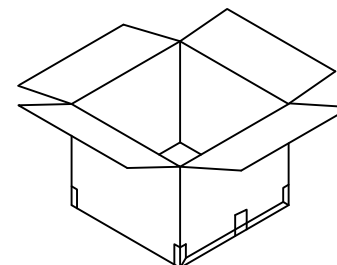
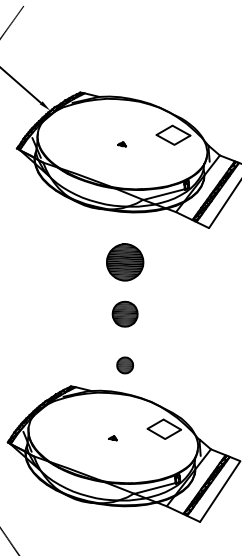

TRANSPARENT GULE TAPE

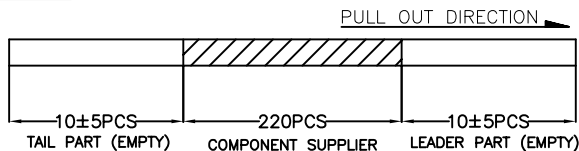
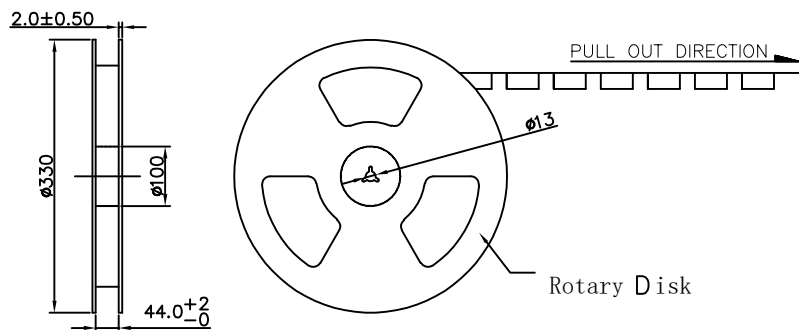
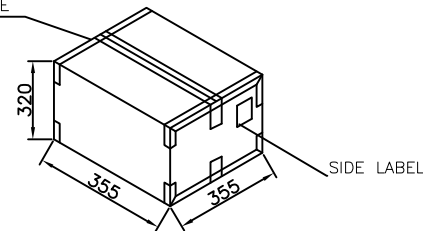

DIANWEI

东莞市钿威电子科技有限公司

DONGGUAN DIANWEI ELECTRONIC TECHNOLOGY CO.,LTD

Tel: +86-769-8788 8322 Fax: +86-769-8788 8321 E-mail: sales@dianwei.cn Http://www.dianwei.cn

UNLESS OTHERWISE SPECIFIED TOLERANCE			
ANG	TOL	DIM	TOL
.X	±3.0°	.X	±0.20
.XX	±2.0°	.XX	±0.10
.XXX	±1.0°	.XXX	±0.05

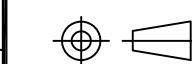

APPROVED

VERIFIED

DESIGN

DRAWING NO

7.03A2-P

PART NAME:

FAKRA HORIZONTAL TYPE CONNECTOR PACKING DRAWING

PART NO.

7.03A2.0008XX

DATE

2023.11.13

UNITS

mm

SCALE

1:1

PAGE

1/1

REV

A

NOTE: ALL RIGHTS RESERVED,BANNED COPY!