

DRAWING TYPE CUSTOMER DRAWING

MARK	DATE	DESCRIPTION	DESIGN
A	2023.11.13	PROPOSAL	CHEN

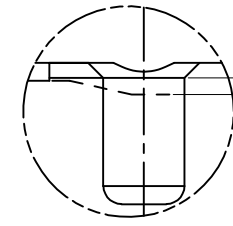

放大图: A
比例: 8:1

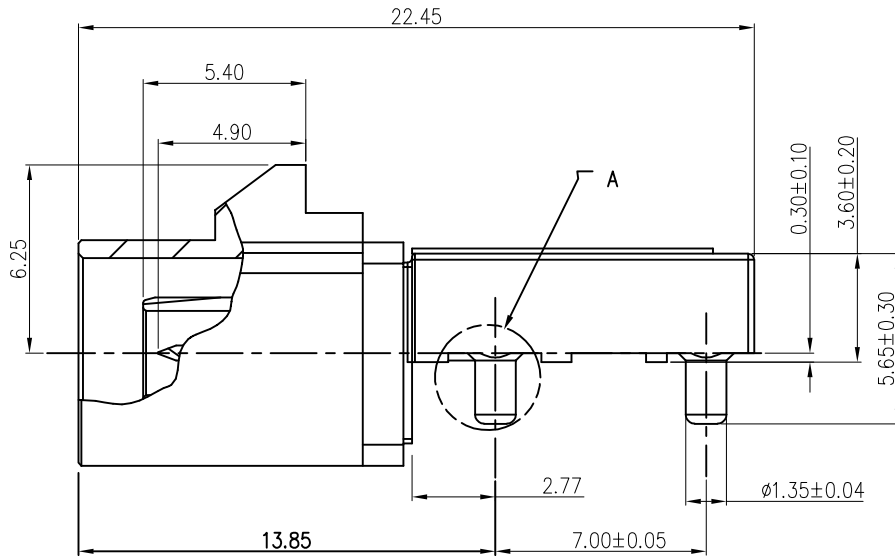
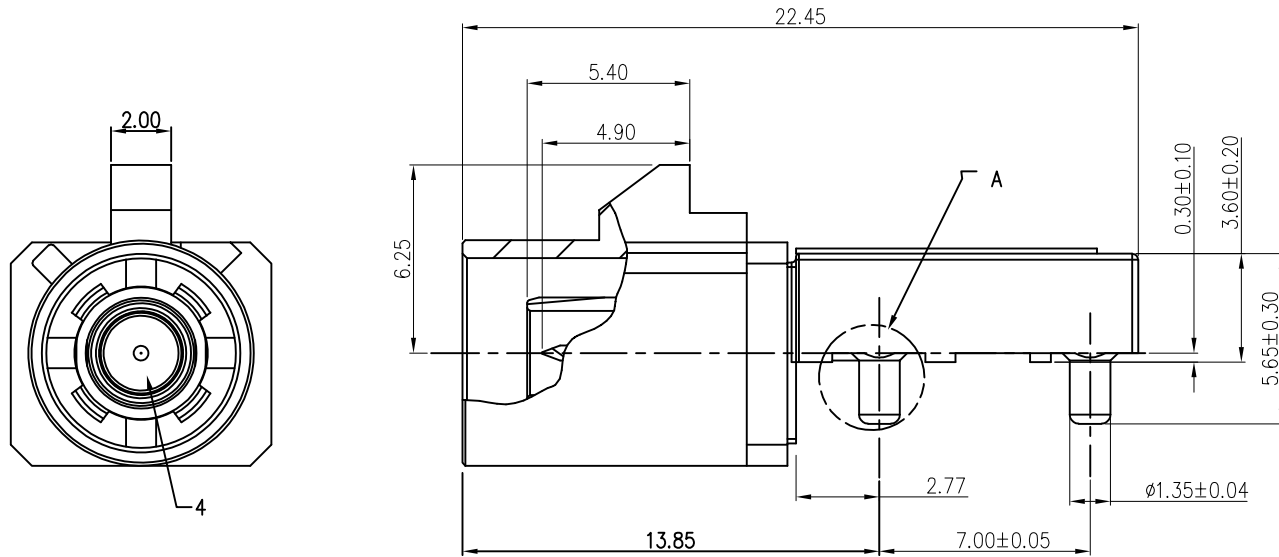
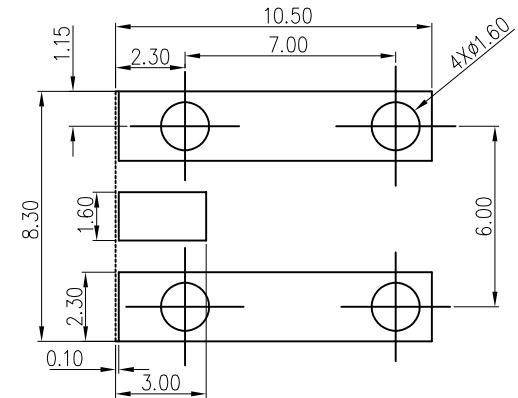

PCB ALL TOLERANCE ±0.05

1. PART NO. LEGEND:

7.03A0 .000 8 2 X

TYPE
CONTACT AREA PLATING SPEC: GOLD PLATING: 8=30u"
SOLDER AREA PLATING SPEC: Tin PLATING: 8=80u"

2. PERFORMANCE:

- 2.1: CONTACT RESISTANCE: INITIAL VALUE 50mOHM Max,
- 2.2: FREQUENCY RANGE:DC to 6GHz
- 2.3 VSWR: 0-6GHz 1.60Max
- 2.4 VOLTAGE RATING: 50V (AC/DC).
- 2.5: CURRENT RATING: 1A/PIN.
- 2.6: INSULATION RESISTANCE: 100MOHM Min.
- 2.7: MATING CYCLES: 25 TIMES Min.
- 2.8: OPERATING TEMPERATURE: -40 °C ~ +105 °C

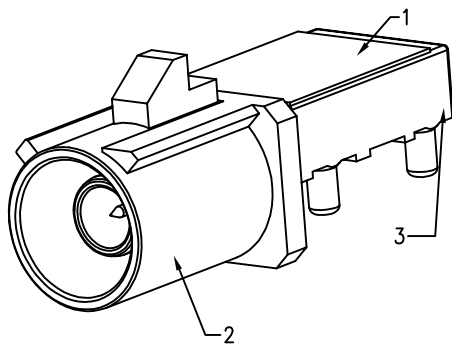
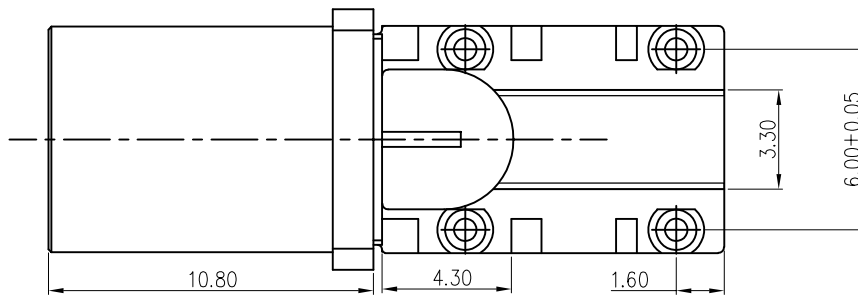

NO.	COMPONENTS	MATERIALS	FINISH/COLOR SPECIFICATION	QUANTITY
4	MOLDING	THERMOPLASTIC+BRASS	BLACK+PLATING GOLD	1
3	BODY	ZINC ALLOY	PLATING Sn	1
2	HOUSING	THERMOPLASTIC UL94V-0	ACCORDANCE WITH THE REQUIREMENTS	1
1	MAYLAR	KAPTON		1

DIANWEI

东莞市钿威电子科技有限公司

DONGGUAN DIANWEI ELECTRONIC TECHNOLOGY CO.,LTD

Tel: +86-769-8788 8322 Fax: +86-769-8788 8321 E-mail: sales@dianwei.cn Http://www.dianwei.cn

UNLESS OTHERWISE SPECIFIED TOLERANCE			
ANG	TOL	DIM	TOL
.X	±3.0°	.X	±0.30
.XX	±2.0°	.XX	±0.20
.XXX	±1.0°	.XXX	±0.10

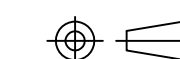

APPROVED

VERIFIED

DRAWING NO

7.03A0-C

PART NAME:

FAKRA LOW PROFILE CONNECTOR CUSTOMER DRAWING

PART NO.

7.03A0.00082X

DATE

2023.11.13

UNITS

mm

SCALE

4:1

PAGE

1/2

REV

A

NOTE: ALL RIGHTS RESERVED,BANNED COPY!

DRAWING TYPE CUSTOMER DRAWING

MARK	DATE	DESCRIPTION	DESIGN
A	2023.11.13	PROPOSAL	CHEN

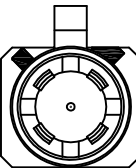
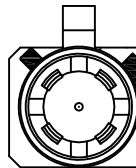
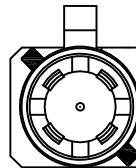
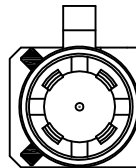
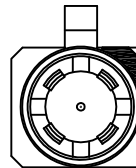
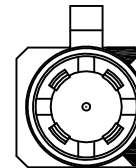
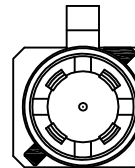
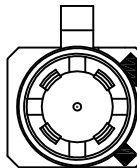
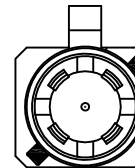
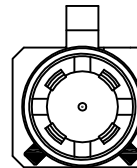
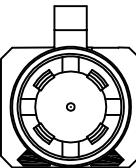
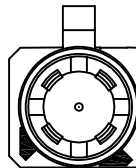
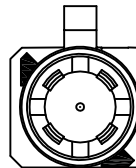
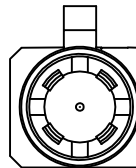
									
7.03A0.000820 A TYPE Black 黑色/9005	7.03A0.000821 B TYPE White 白色/9001	7.03A0.000822 C TYPE Blue 蓝色/5005	7.03A0.000823 D TYPE Bordeaux 枣红色/4004	7.03A0.000824 E TYPE Green 绿色/6002	7.03A0.000825 F TYPE Brown 棕色/8011	7.03A0.000826 G TYPE Grey 灰色/7031	7.03A0.000827 H TYPE Violet 紫罗兰/4003	7.03A0.000828 I TYPE Beige 米黄色/1001	7.03A0.000829 K TYPE Curry 咖喱色/1027
									
7.03A0.00082A L TYPE Camine Red 深红/3002	7.03A0.00082B M TYPE Pastel Orange 粉橙色/2003	7.03A0.00082C N TYPE Pastel Green 粉绿色/6019	7.03A0.00082D Z TYPE Water Blue 水蓝色/5021						

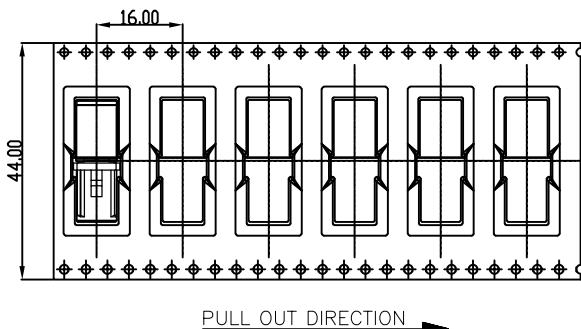

NOTE:
1.PER REEL: 400PCS

NOTE: ALL RIGHTS RESERVED, BANNED COPY!

UNLESS OTHERWISE SPECIFIED TOLERANCE			
ANG	TOL	DIM	TOL
.X	±3.0°	.X	±0.30
.XX	±2.0°	.XX	±0.20
.XXX	±1.0°	.XXX	±0.10

DIANWEI

DONGGUAN DIANWEI ELECTRONIC TECHNOLOGY CO.,LTD
Tel: +86-769-8788 8322 Fax: +86-769-8788 8321 E-mail: sales@dianwei.cn Http://www.dianwei.cn

东莞市钿威电子科技有限公司

FAKRA LOW PROFILE CONNECTOR
PACKING DRAWING

APPROVED	VERIFIED	DRAWING NO	PART NAME:			
		7.03A0-C	FAKRA LOW PROFILE CONNECTOR PACKING DRAWING			
DESIGN	CHEN	PART NO.		7.03A0.00082X		
		DATE	UNITS	SCALE	PAGE	REV
		2023.11.13	mm	4:1	2/2	A

DRAWING TYPE PACKAGE DRAWING

MARK	DATE	DESCRIPTION	DESIGN
A	2023.11.13	PROPOSAL	CHEN

NOTES:

1. MATERIAL:
 - 1.1 CARRY TAPE:HIPS, T=0.50±0.05mm, BLACK
 - 1.2 REEL:HIPS,
 - 1.3 SHIM:PE, CLEAR.
2. PRIMARY PACKING:400PCS/REEL
3. SECONDARY PACKING:SEE PACKING LIST
4. PEELING RESISTANCE: 0.2~1.2N(20~120gf); PEELING ANGLE: 165° ~180° ; PEELING SPEED: 300mm/minutes.

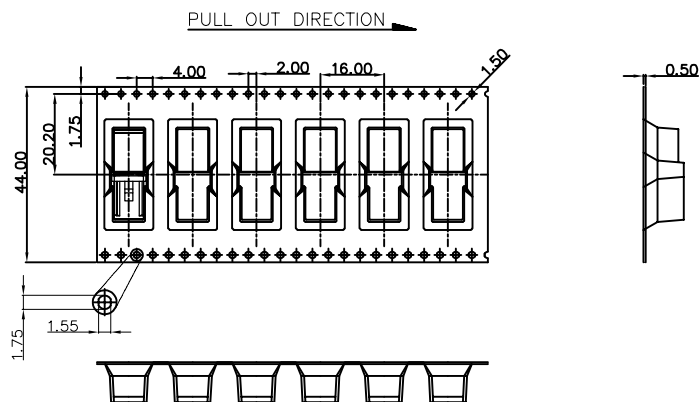

PER REEL with PE Bag

TOTAL 6 LAYERS

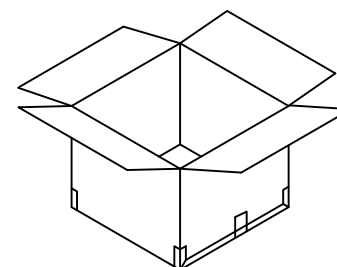
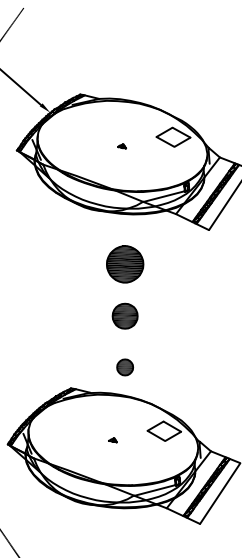

TRANSPARENT GULE TAPE

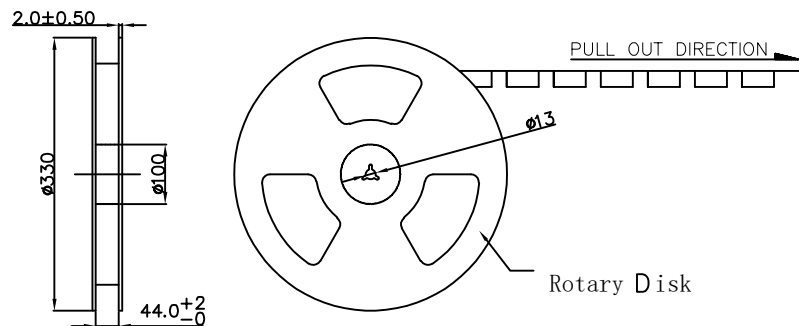
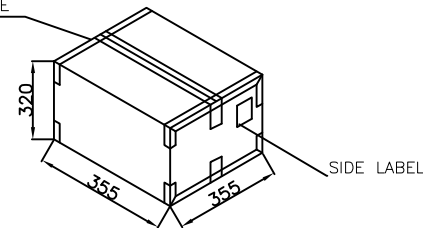

Rotary Disk

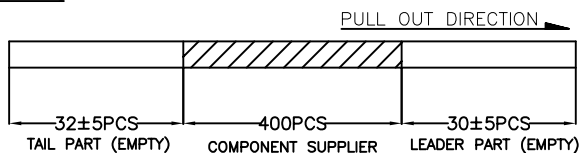

DIANWEI

东莞市钿威电子科技有限公司

DONGGUAN DIANWEI ELECTRONIC TECHNOLOGY CO.,LTD

Tel: +86-769-8788 8322 Fax: +86-769-8788 8321 E-mail: sales@dianwei.cn Http://www.dianwei.cn

UNLESS OTHERWISE SPECIFIED TOLERANCE			
ANG	TOL	DIM	TOL
.X	±3.0°	.X	±0.20
.XX	±2.0°	.XX	±0.10
.XXX	±1.0°	.XXX	±0.05

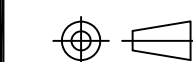

APPROVED

VERIFIED

DRAWING NO

7.03A0-P

DESIGN

CHEN

PART NAME:

FAKRA LOW PROFILE CONNECTOR PACKING DRAWING

PART NO.

7.03A0.0008XX

DATE

2023.11.13

UNITS

mm

SCALE

1:1

PAGE

1/1

REV

A

NOTE: ALL RIGHTS RESERVED,BANNED COPY!