

MARK	DATE	DESCRIPTION	DESIGN

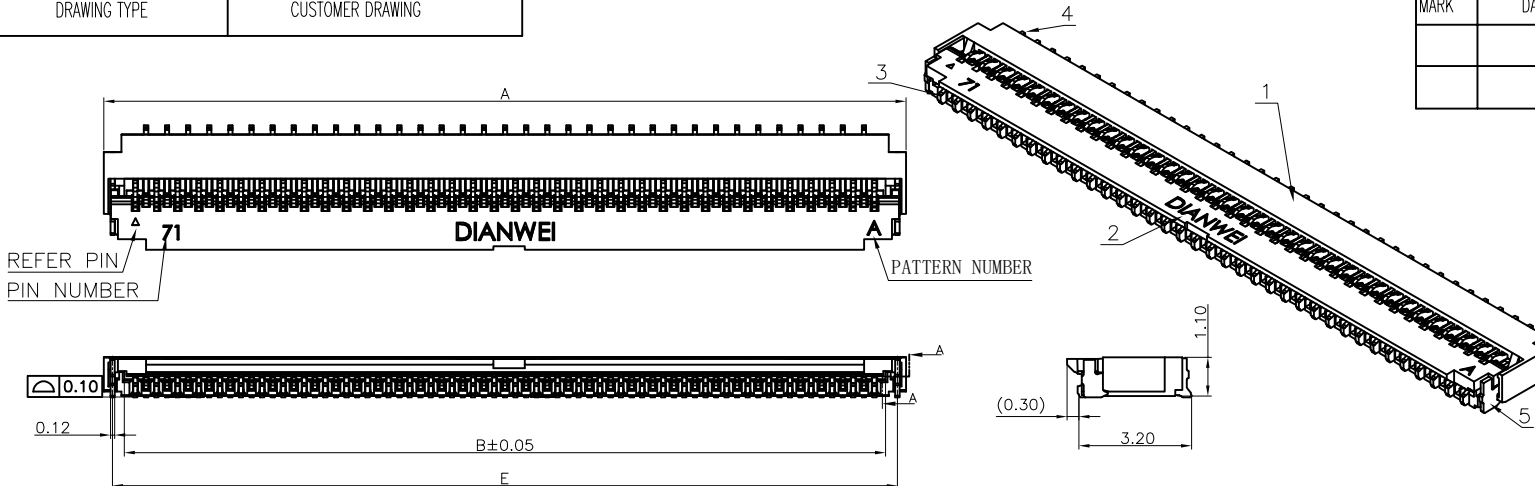

1. PART NO. LEGEND:  
 8.26A2 . \*\*\* 2 0 0  
 ① ② ③ ④ ⑤  
 1. 1. SERIES NAME:8.26A2=0.3MM FFC/FPC SWING COVER CONNECTOR(H=1.1mm)  
 1. 2. CONTACT PIN NUMBER:\*\*\*=CONTACT PIN NUMBER  
 1. 3. CONTACT AREA PLATING SPEC:GOLD PLATING:2=1~3u";3=5u";4=10u";5=15u"  
 SOLDER AREA PLATING SPEC:GOLD PLATING:2=1~3u";3=5u";4=10u";5=15u"  
 1. 4. UNSPECIFIED:0=NONSENSE  
 1. 5. UNSPECIFIED:0=NONSENSE  
 2. PERFORMANCE:  
 2. 1. CURRENT RATING:0.2A/PIN.  
 2. 2. VOLTAGE RATING:30V(AC/DC).  
 2. 3. CONTACT RESISTANCE:INITIAL VALUE 100mOHM Max,  
 2. 4. INSULATION RESISTANCE:50mOHM Min.  
 2. 5. DIELECTRIC WITHSTANDING VOLTAGE:100V AC FOR 1 MINUTE;  
 2. 6. DURABILITY:20 TIMES Min.  
 2. 7. OPERATING TEMPERATURE:-40℃~+85℃  
 OPERATING HUMIDITY RANGE:20% TO 85%

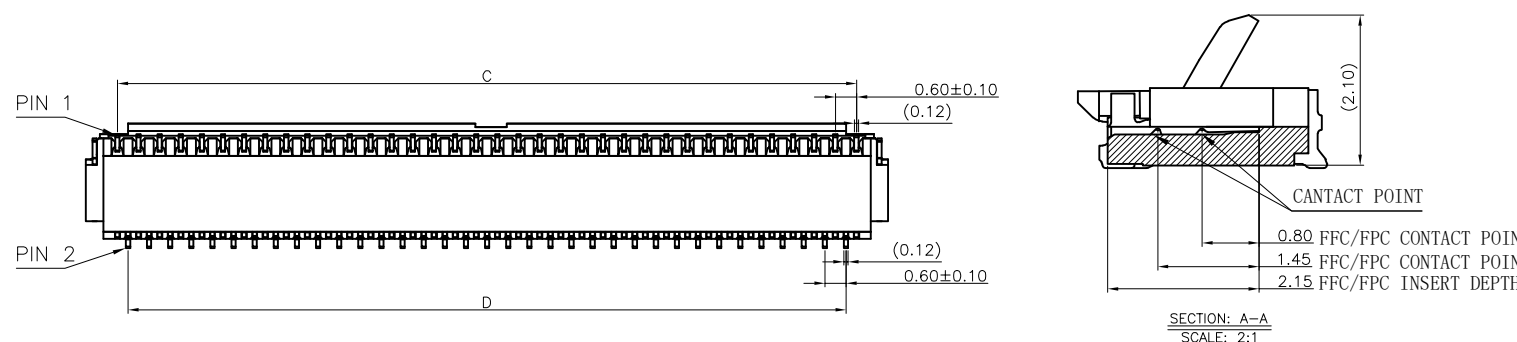

Pin Number	Part Number	DIM A	DIM B	DIM C	DIM D	DIM E	DIM F
13	8.26A2.013200	5.40	4.23	3.60	3.00	4.90	4.20
15	8.26A2.015200	6.00	4.83	4.20	3.60	5.50	4.80
17		6.60	5.43	4.80	4.20	6.10	5.40
19	8.26A2.019200	7.20	6.03	5.40	4.80	6.70	6.00
21	8.26A2.021200	7.80	6.63	6.00	5.40	7.30	6.60
23		8.40	7.23	6.60	6.00	7.90	7.20
25	8.26A2.025200	9.00	7.83	7.20	6.60	8.50	7.80
27	8.26A2.027200	9.60	8.43	7.80	7.20	9.10	8.40
29		10.20	9.03	8.40	7.80	9.70	9.00
31	8.26A2.031200	10.80	9.63	9.00	8.40	10.30	9.60
33		11.40	10.23	9.60	9.00	10.90	10.20
35	8.26A2.035200	12.00	10.83	10.20	9.60	11.50	10.80
37		12.60	11.43	10.80	10.20	12.10	11.40
39	8.26A2.039200	13.20	12.03	11.40	10.80	12.70	12.00
41		13.80	12.63	12.00	11.40	13.30	12.60
45	8.26A2.045200	15.00	13.83	13.20	12.60	14.50	13.80
51	8.26A2.051200	16.80	15.63	15.00	14.40	16.30	15.60
57	8.26A2.057200	18.60	17.43	16.80	16.20	18.10	17.40
61	8.26A2.061200	19.80	18.63	18.00	17.40	19.30	18.60
71		22.80	21.63	21.00	20.40	22.30	21.60

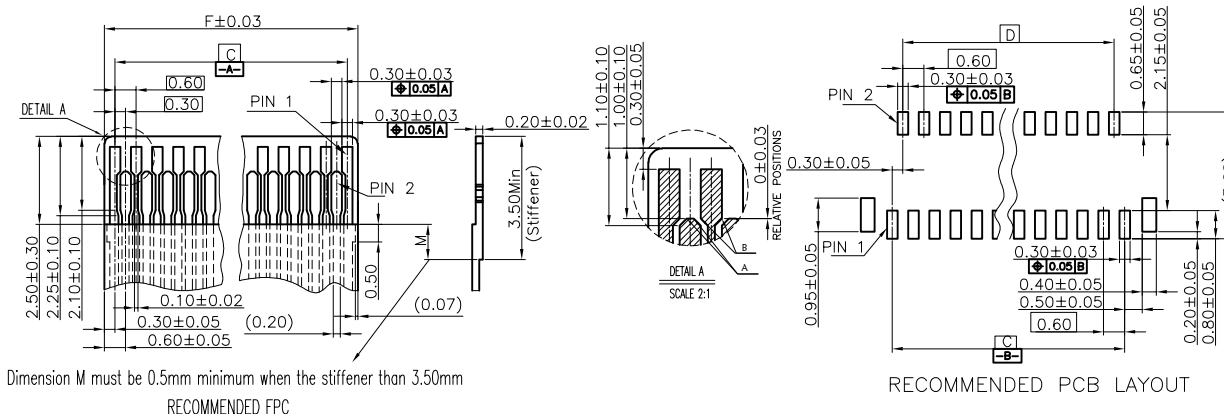

Dimension M must be 0.5mm minimum when the stiffener than 3.50mm  
 RECOMMENDED FPC

5	STATOR	PHOSPHOR BRONZE	Sn	2
4	TERMINAL II	PHOSPHOR BRONZE		POSITIONS
3	TERMINAL I	PHOSPHOR BRONZE		POSITIONS
2	COVER	THERMOPLASTIC UL94V-0	BLACK	1
1	HOUSING	THERMOPLASTIC UL94V-0	BLACK	1
NO.	COMPONENTS	MATERIALS	FINISH/COLOR SPECIFICATION	QUANTITY

**DIANWEI** 东莞市钿威电子科技有限公司  
 DONGGUAN DIANWEI ELECTRONIC TECHNOLOGY CO., LTD  
 Tel: +86-769-8788 8322 Fax: +86-769-8788 8321 E-mail: sales@dianwei.cn Http://www.dianwei.cn

UNLESS OTHERWISE SPECIFIED TOLERANCE

ANG	TOL	DIM	TOL
.X	±3.0°	.X	±0.30
.XX	±2.0°	.XX	±0.20
.XXX	±1.0°	.XXX	±0.10

APPROVED	VERIFIED	DESIGN	DRAWING NO	PART NAME:	0.3MM FFC/FPC SWING COVER CONNECTOR(H=1.1mm)			
			8.26A2-C	PART NO.	8.26A2-***200			
		CHEN	DATE	UNITS	SCALE	PAGE	REV	
			2023.08.07	mm	1:1	1/1	A	

NOTE: ALL RIGHTS RESERVED, BANNED COPY!

DRAWING TYPE PACKAGE DRAWING

MARK	DATE	DESCRIPTION	DESIGN

PULL OUT DIRECTION

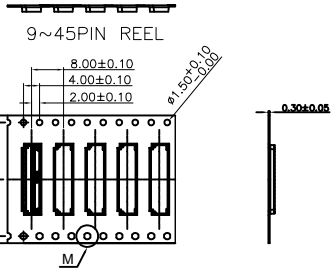
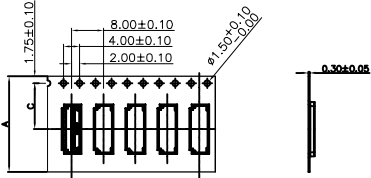

NOTES:

- MATERIAL:
  - CARRY TAPE:HIPS,T=0.30±0.05mm,CLEAR
  - REEL:HIPS,
  - SHIM:PE,CLEAR.
- PRIMARY PACKING:3000PCS/REEL.
- SECONDARY PACKING:SEE PACKING LIST
- PEELING RESISTANCE: 0.1~1.3N(10~130gf); PEELING ANGLE: 165°~180°; PEELING SPEED: 300mm/minutes.

每盘使用PE带真空包装

TOTAL N LAYERS

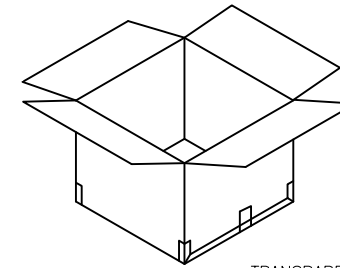
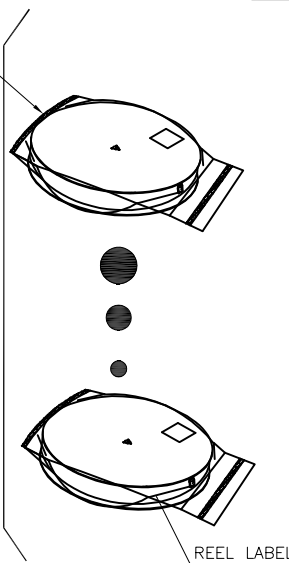

TRANSPARENT GULE TAPE

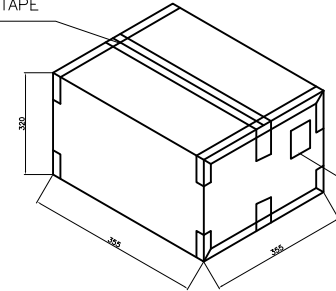

SIDE LABEL

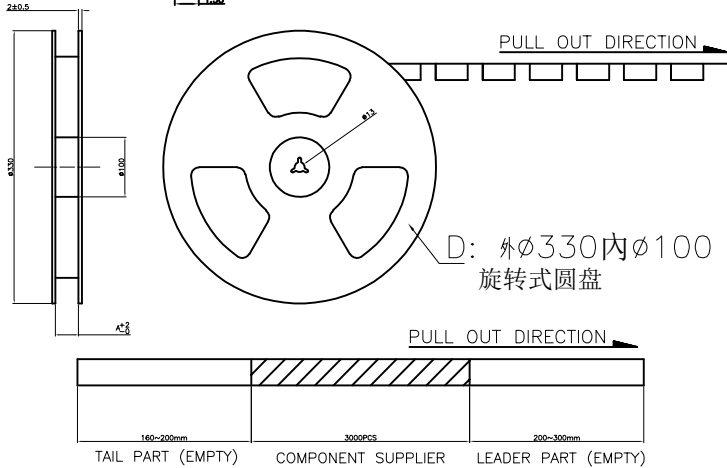

6. QTY. LIST:

NO. OF POS.	A	B	C	PCS/REEL
9~19 PIN	16.0	—	7.5	3000
21~45 PIN	24.0	—	11.5	3000
47~61 PIN	32.0	28.4	14.2	3000
71 PIN	44.0	40.4	20.2	3000

NOTE: ALL RIGHTS RESERVED,BANNED COPY!

UNLESS OTHERWISE SPECIFIED TOLERANCE			
ANG	TOL	DIM	TOL
.X	±3.0°	.X	±0.30
.XX	±2.0°	.XX	±0.20
.XXX	±1.0°	.XXX	±0.10

**DIANWEI**

东莞市钿威电子科技有限公司

DONGGUAN DIANWEI ELECTRONIC TECHNOLOGY CO.,LTD

Tel: +86-769-8788 8322 Fax: +86-769-8788 8321 E-mail: sales@dianwei.cn Http://www.dianwei.cn

APPROVED	VERIFIED	DESIGN	DRAWING NO		PART NAME:		
			8.26A*-P		0.3mm FFC/FPC DUAL CONTACT SIDE CONNECTOR(H=0.9mm)PACKAGE SPEC		
		CHEN	PART NO.		8.26A***200		
			DATE	UNITS	SCALE	PAGE	REV
			2023.08.07	mm	1:1	1/1	A