

DRAWING TYPE

CUSTOMER DRAWING

MARK

DATE

DESCRIPTION

DESIGN

A

NEW DRAWING

Ming Yuan

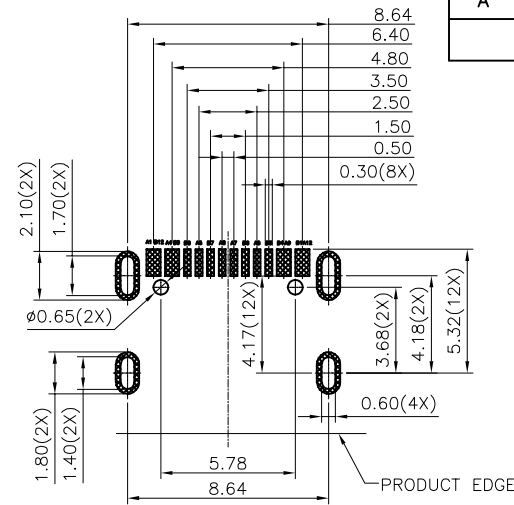
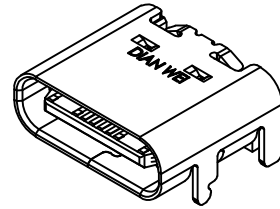
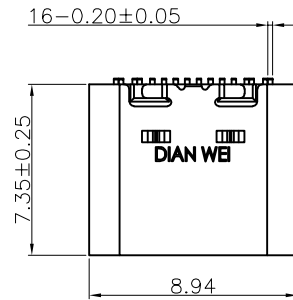

RECOMMENDED PCB LAYOUT(TOP VIEW)
THICKNESS 0.80MM;DEFAULT TOLERANCE:±0.05

Pin	Signal Name	Mating Sequence	Pin	Signal Name	Mating Sequence
A1	GND	First	B12	GND	First
/					
A4	V _{BUS}	First	B9	V _{BUS}	First
A5	CC1	Second	B8	SBU2	Second
A6	Dp1	Second	B7	Dn2	Second
A7	Dn1	Second	B6	Dp2	Second
A8	SBU1	Second	B5	CC2	Second
A9	V _{BUS}	First	B4	V _{BUS}	First
/					
A12	GND	First	B1	GND	First
SHELL	GND		SHELL	GND	

NOTES:

- MATERIAL: SEE "TABLE 1";
- FINISH: SEE "TABLE 1";

3. ELECTRICAL :

- CONTACT CURRENT RATING :
12A(V_{BUS} PIN AND GND PIN),
- INSULATION RESISTANCE :
100 MEGAΩ MIN. AT 200VDC.
- DIELECTRIC WITHSTANDING VOLTAGE :
100VAC MIN.
- LOW LEVEL CONTACT RESISTANCE :
INITIAL 40mΩ MAX.
AFTER 50mΩ MAX.

4. MECHANICAL CHARACTERISTICS :

- MATING FORCE: 5~20N;
- UNMATING FORCE: 8~20N(INITIAL),6~20N(AFTER 10000 CYCLES);
- DURABILITY : 10,000 MATING CYCLES.
- OPERATING TEMPERATURE : -40°C TO +80°C

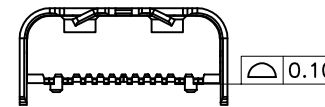
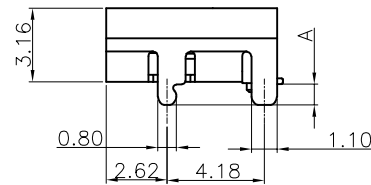
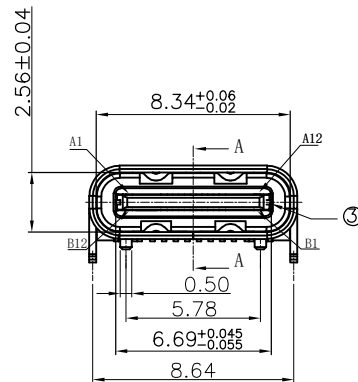

PART NO. INSTRUCTIONS:
2.01AX.016X0X

0:black
1:white

序号	A尺寸
1	0.90
2	1.20
3	1.60

TABLE 1:

NO.	PART NAME	QTY	MATERIAL	DESCRIPTION	REMARK
④	Shell	1	Stainless steel	Ni:50U ^{MIN} PLATING;	T=0.30mm
③	MID PLATE	1	Stainless steel	Ni:50U ^{MIN} PLATING;	T=0.20mm
②	Terminal	16	Copper alloy	SEE PART NO. INSTRUCTIONS	T=0.25mm
①	Molding	3	HIGH TEMP	SEE PART NO. INSTRUCTIONS	

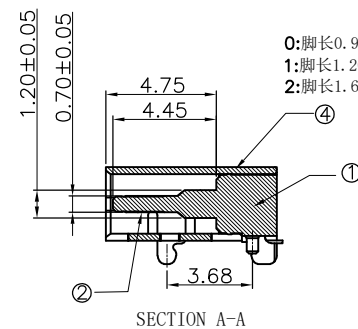
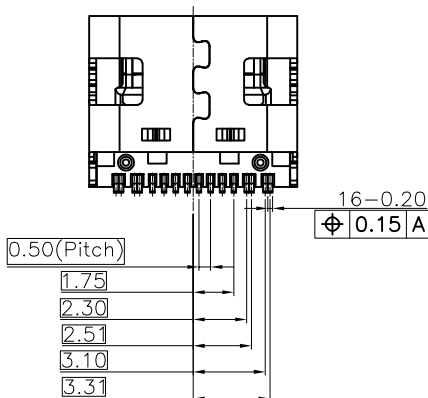

0:脚长0.90
1:脚长1.20
2:脚长1.60

2 :Gold plated 1U"
3 :Gold plated 5U"
4 :Gold plated 10U"
5 :Gold plated 15U"
8 :Gold plated 30U"
A :Gold plated 3U"

UNLESS OTHERWISE
SPECIFIED TOLERANCE

ANG	TOL	DIM	TOL
.X	±5°	.X	±0.38
.XX	±3°	.XX	±0.20
.XXX	±1°	.XXX	±0.10

DIANWEI

DONGGUAN DIANWEI ELECTRONIC TECHNOLOGY CO.,LTD

Fax: +86-769-8788 8321 E-mail: sales@dianwei.cn Http://www.dianwei.cn

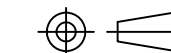

DRAWING NO

PART NAME:

TYPE C F 板上型16PIN SMT
客户图

APPROVED

VERIFIED

DESIGN

PART NO.

2.01AX.016X0X

DATE

UNITS

SCALE

PAGE

REV

表明

2022.05.26

mm

1:1

1/1

A

DRAWING TYPE

PACKAGE DRAWING

MARK

DATE

DESCRIPTION

DESIGN

A

NEW DRAWING

Ming Yuan

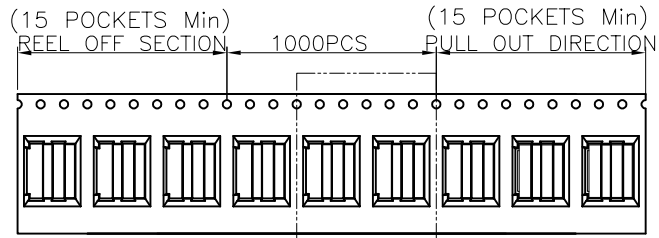

SEE DETAIL X

PEELING DIRECTION
165°~180°
PEELING ANGLE

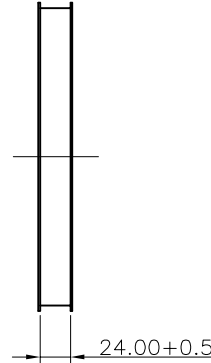
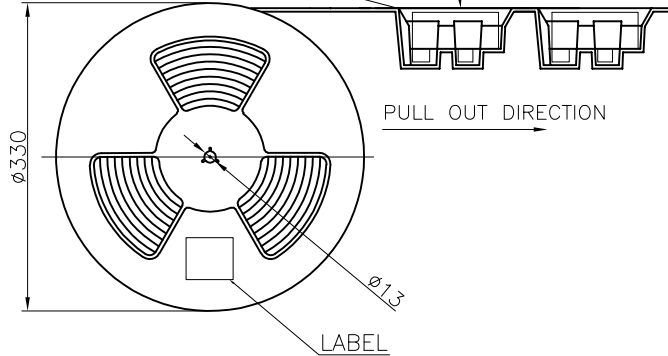

PAPER BOARD

REEL AND TAPE

REEL AND TAPE

PAPER BOARD

FOLDER
PAPER BOARD

CARTON

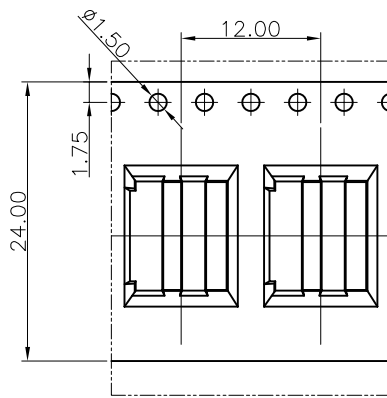
REEL OFF
DIRECTION

DETAIL X

PULL OUT
DIRECTION

	REEL	CARTON
CONNECTOR (PCS)	1000	10000

UNLESS OTHERWISE
SPECIFIED TOLERANCE

ANG	TOL	DIM	TOL
.X	$\pm 2.0^\circ$.X	± 0.10
.XX	$\pm 1.0^\circ$.XX	± 0.05
.XXX	$\pm 0.5^\circ$.XXX	± 0.03

DIANWEI

东莞市钲威电子科技有限公司

DONGGUAN DIANWEI ELECTRONIC TECHNOLOGY CO.,LTD

Fax: +86-769-8788 8321 E-mail: sales@dianwei.cn Http://www.dianwei.cn

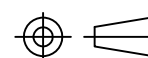

APPROVED

VERIFIED

DESIGN

表明

DRAWING NO

PART NAME:

TYPE C F 板上型16PIN SMT
客户图

PART NO.

2.01A0.016X0X

DATE

2022.05.26

UNITS

mm

SCALE

1:1

PAGE

1/1

REV

A

QP-04-33-B